

ITEM NO.	PART NUMBER	DESCRIPTION	QTY.
1	21378	BODY	1
2	08490	BEARING	2
3	19308	SHAFT	1
4	06837	RET. RING	1
5	05126	RET. RING	1
6	19275	HUB	1
7	18652	SEAL, LIP	1
8	04432	WOODRUFF KEY	1
9	10944	CAM	1
10	19995	SCREW 1/4-20 ROUND HD	1
11	19996	CAM WASHER	1
12	10615	RUBBER IMPELLER	1
13	21120	COVER PLATE	1
14	2220-0099	SHCS #10-24UNC x 3/8	4
15	12231	O-RING	1
16	00343	LOCK WASHER	4

PART NUMBER **P105**

- NOTES:
- (E) 1. REMOVED NOTE, SEE REV. E
 - 2. APPLY SIL-GLYDE TO SEAL LIP I.D. PRIOR TO SHAFT INSTALLATION.
 - 3. APPLY BEAD OF PERMATEX AROUND CAM SCREW THREADED HOLE PRIOR TO ASSEMBLY.
 - 4. STAMP "P105" AND DATE CODE IN LOCATION AS SHOWN.
 - (D) 5. APPLY SIL-GLYDE TO INSIDE LIP OF SEAL, LIP.

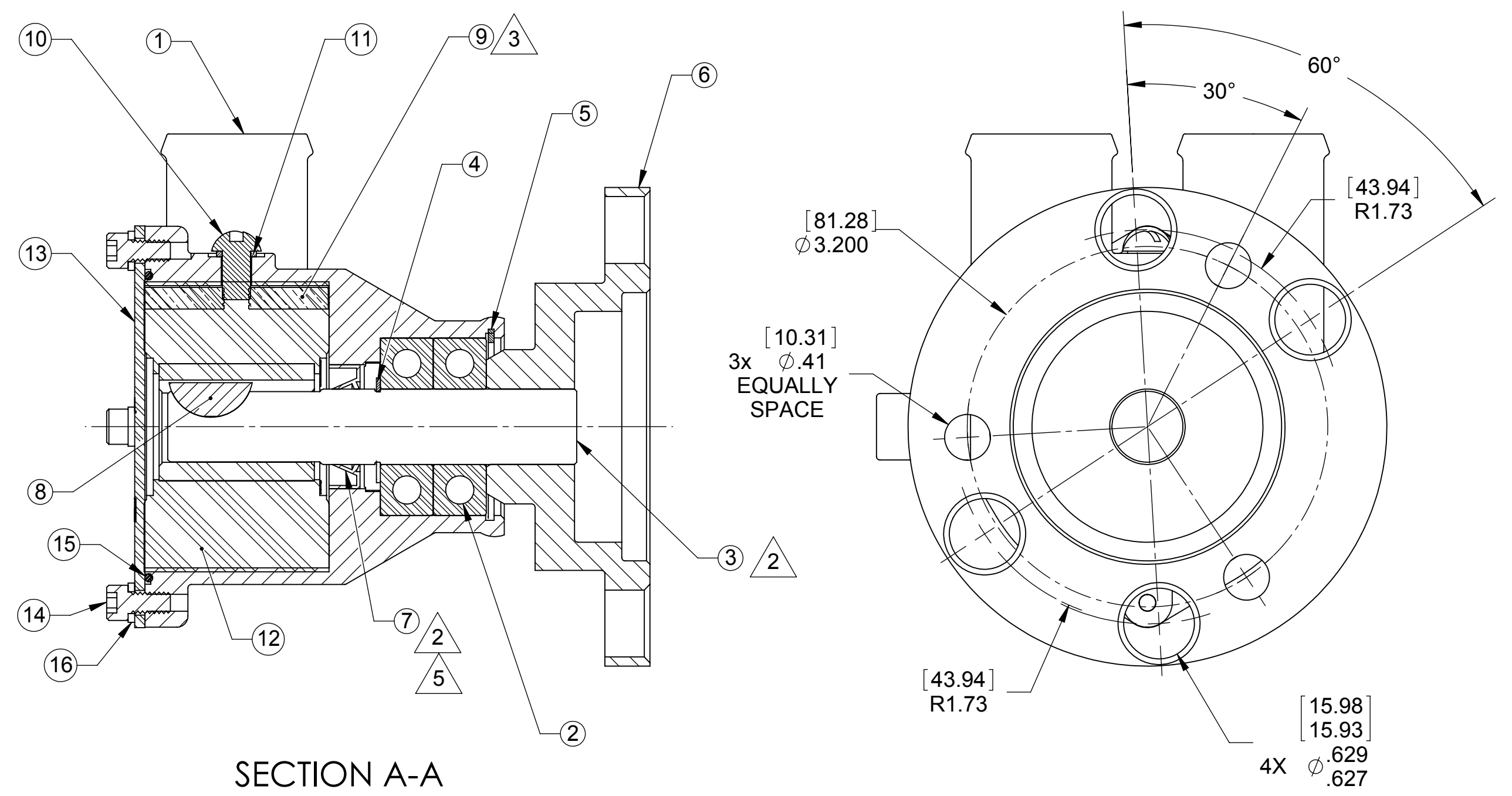
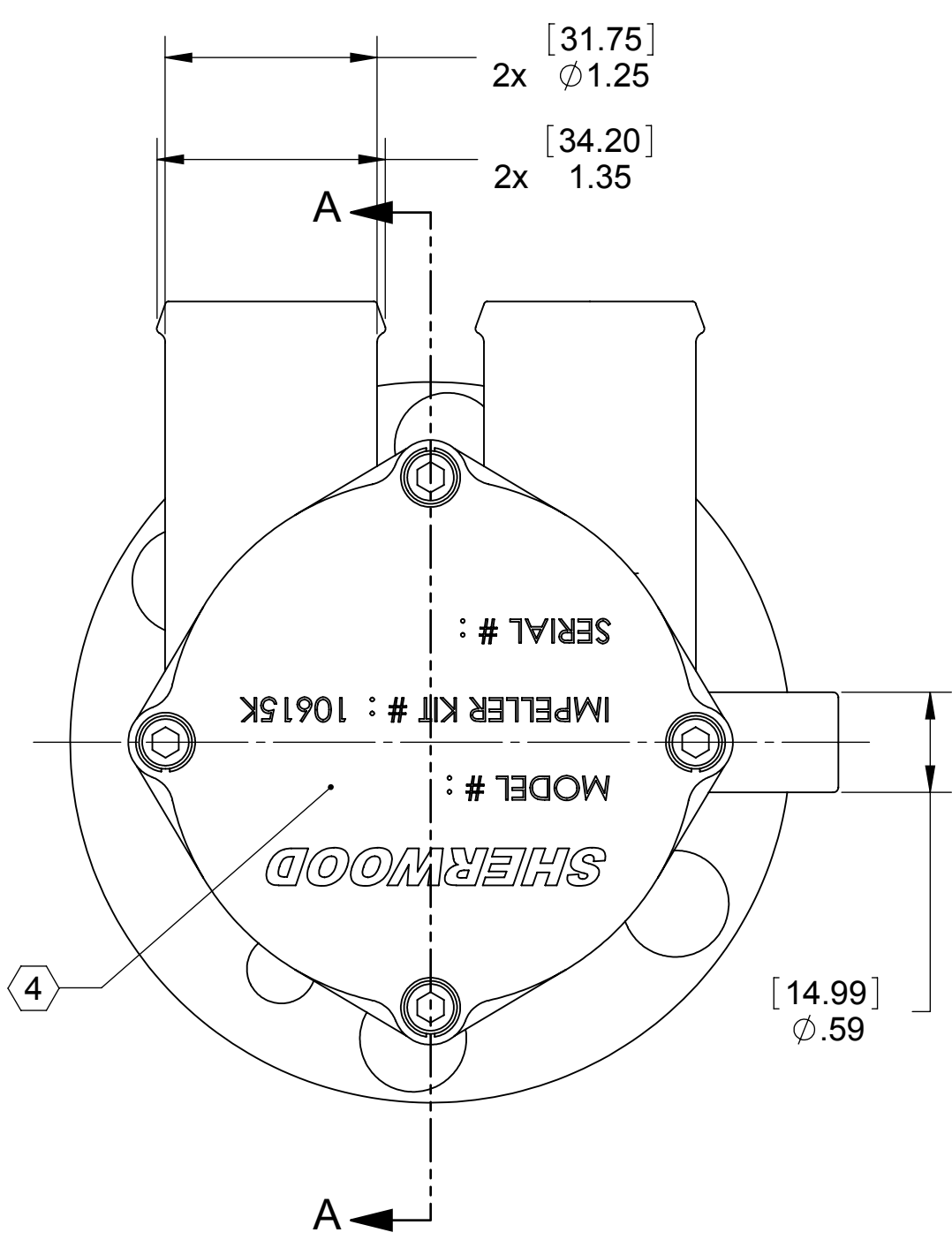
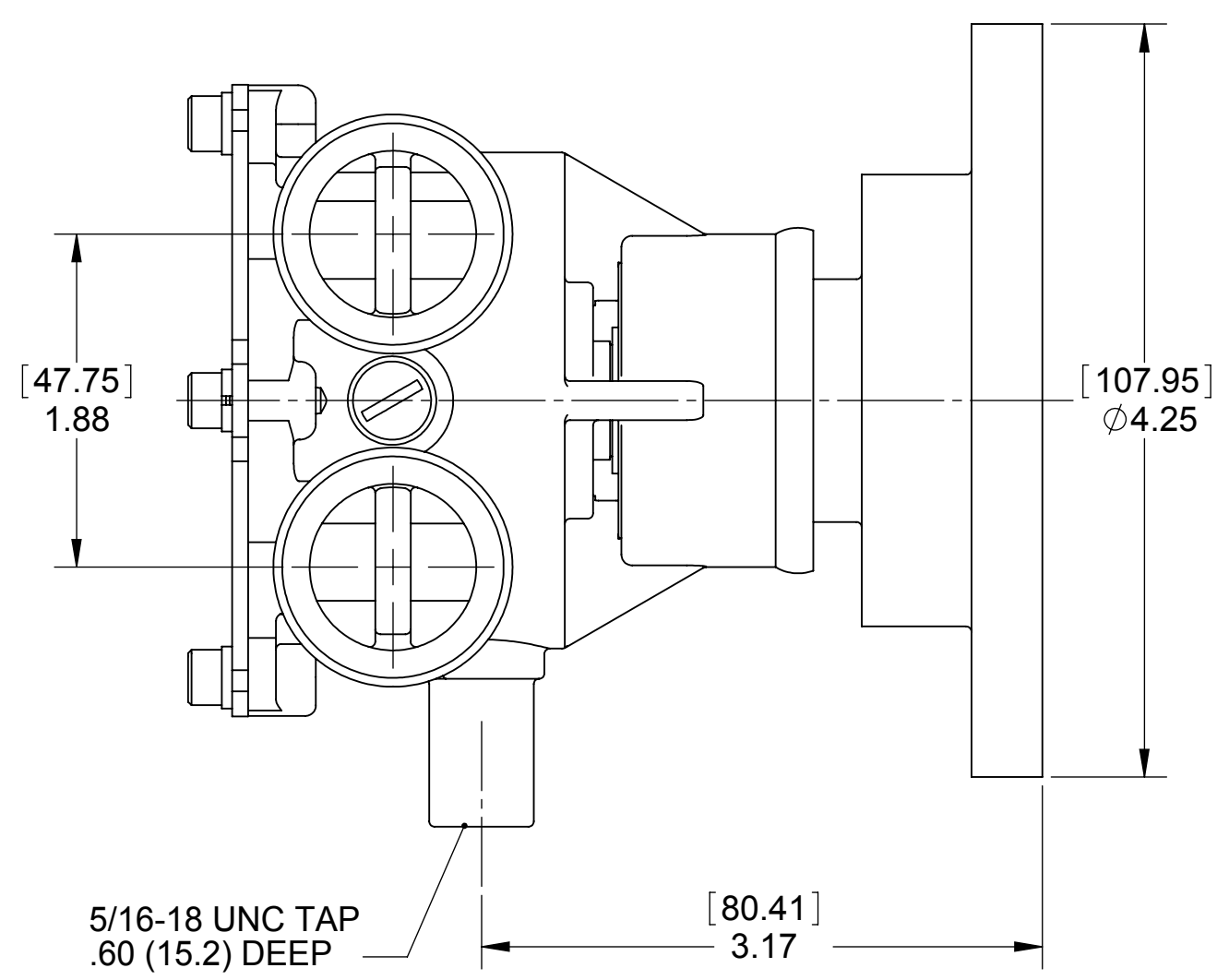

SECTION A-A

REV.	ECN	DESCRIPTION	CHKD	DATE
E	7036	REMOVED NOTE 1.	JJH	8/22/2008
D	5942	ADDED NOTE 5	DV	10/11/2006
C	5763	REVISED NOTES, CHG COVER STAMP TO P105, WAS RA0570026	RJE	7/10/2006
B	3765	ITEM 16 WAS 00344 SCREW	DV	10/29/2003
A	1931	RELEASE NEW ASSY TO PRODUCTION	DV	8/2/2002

SHERWOOD
A Div. of Hypro Corporation A PENTAIR COMPANY
375 Fifth Avenue NW, New Brighton, MN 55112, (651) 766-6300

DRAWING BASED ON ASME Y14.5M-1994 DO NOT SCALE PRINT

SCALE 1:1 SHEET NUMBER 1 OF 1

PART DESCRIPTION **RUBBER IMPELLER PUMP**

REPLACES PART NO. _____ REV. _____

DWG BY: FLA DATE: 8/1/2002

CHECKED BY: _____ DATE: _____

APPROVED BY: _____ DATE: _____

THIS DRAWING IS THE PROPERTY OF HYPRO, AND WITHOUT WRITTEN AUTHORIZATION, MUST NOT BE COPIED OR COMMUNICATED

PART NUMBER **P105** REV. **E**