

JPR-YM06LY2

PART LIST					
No.	QTY	PART NUMBER	PART NAME	MAT	DESCRIPTION
1	1	PUA0140	PUMP ASSY		JPR-YM06LY2

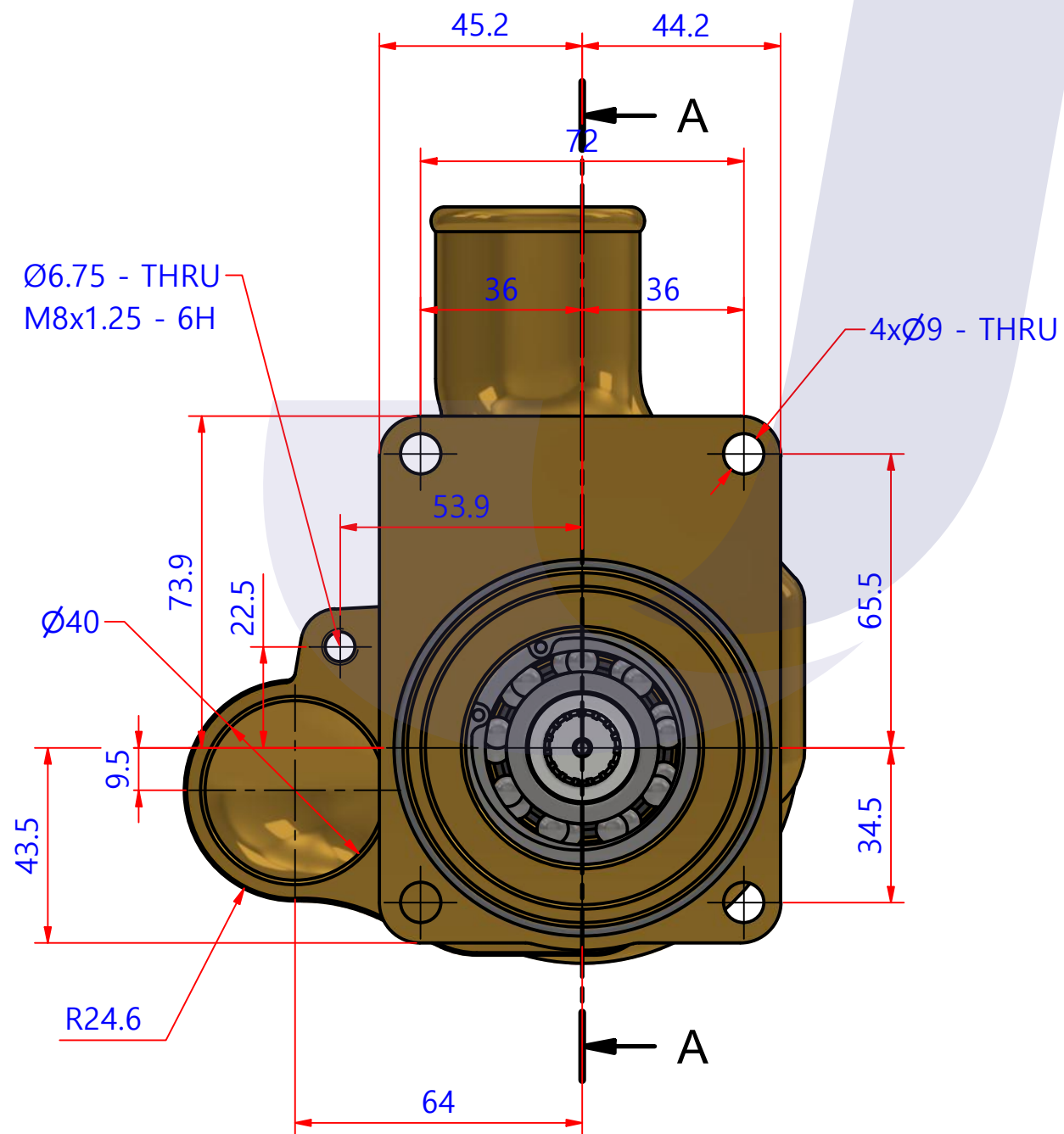
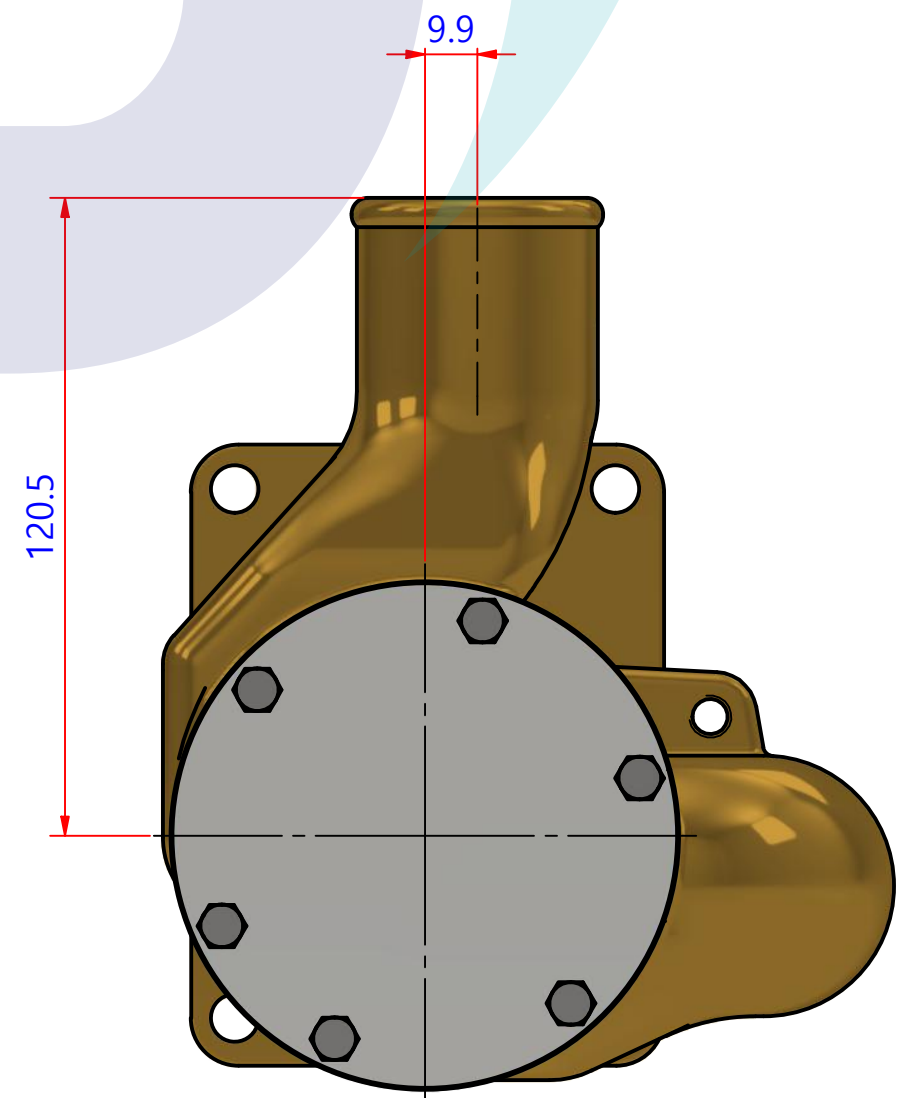
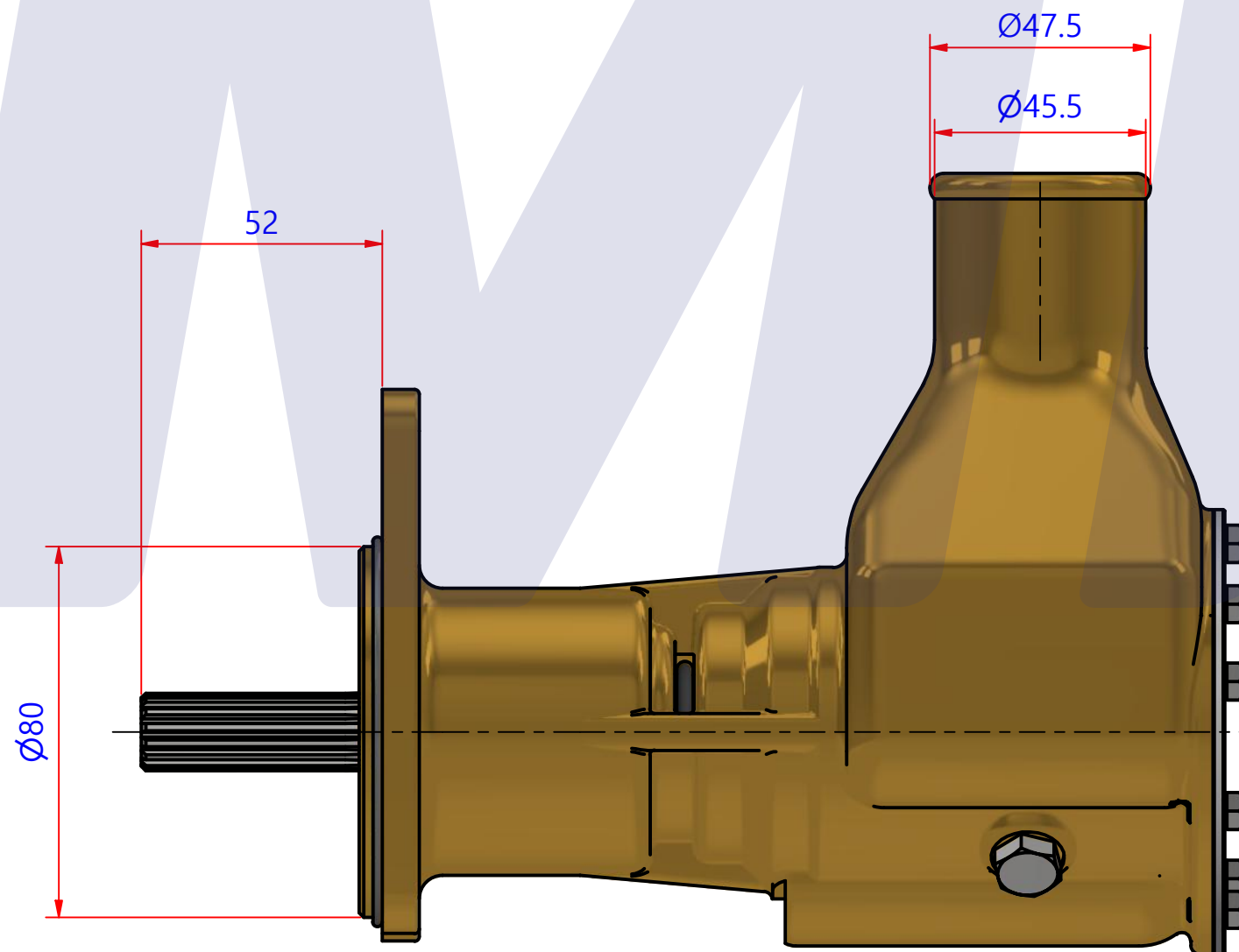
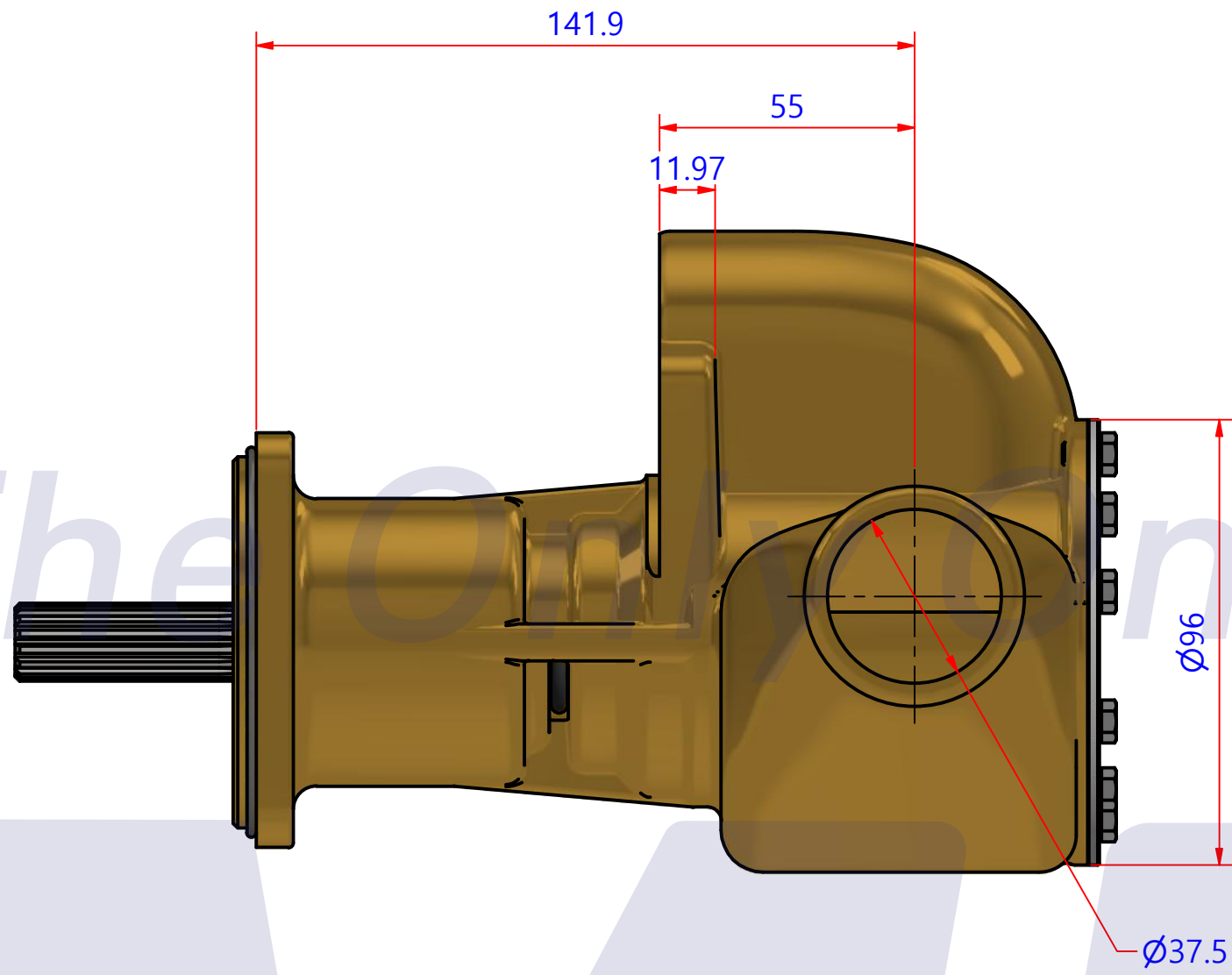
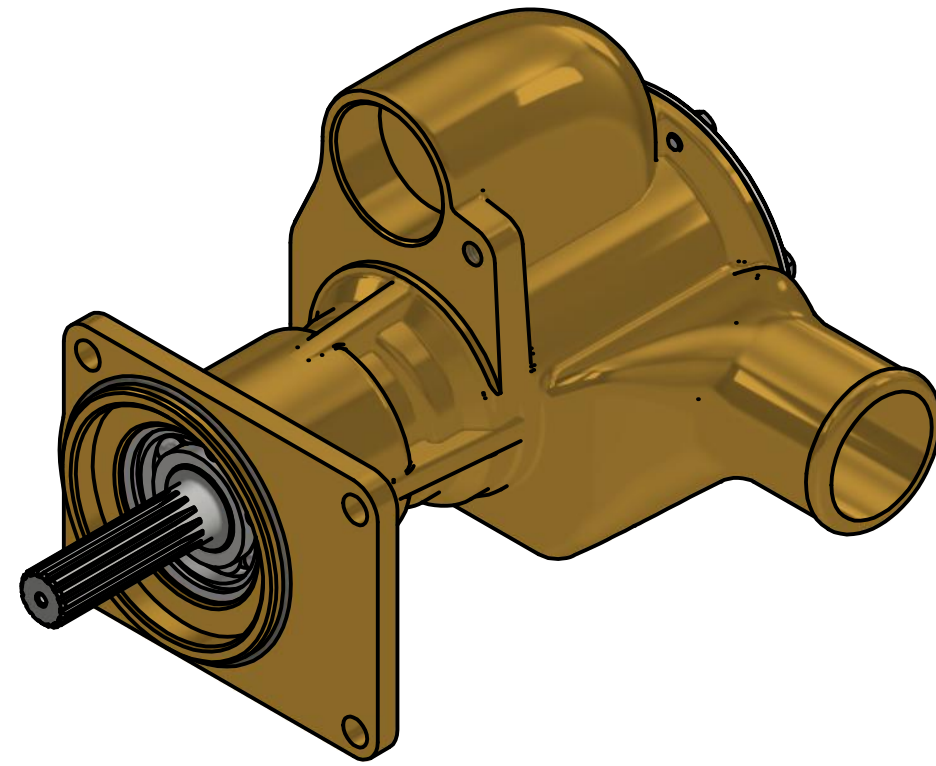

Drawing by	Checked by	Approved by - date	Model Name	Date	Scale
강 명 진	C.I, JEON		JPR-YM06LY2	2016-09-27	1 : 1
			PUMP ASSY		
			PART NUMBER	PUA0140(0)	Sheet A2

품 번	PUA0140
품 명	JPR-YM06LY2

A: MAJOR KIT B: MINOR KIT C: CAM SET D: M-SEAL SET E: IMPELLER KIT

No.	QTY	PART NUMBER	PART NAME	A (JSK0128)	B (JSM0128)	C (CAMSET0041)	D (MCSSET0021)	E (JIKJMP062)
1	2	BER0004	BEARING	X				
2	1	BOL0031	BRONZE WASHER	X	X	X		
3	1	BOL0137	HEX BOLT	X	X	X		
4	6	BOL0163	HEX BOLT	X	X			
5	1	CAM0041	CAM	X	X	X		
6	1	COV0055	COVER	X	X			
7	1	7376-01	RUBBER IMPELLER	X	X			X
8	1	MCS0042	CARBON	X	X		X	
9	1	MCS0043	CERAMIC	X	X		X	
10	1	ORG0014	O-RING	X				
11	1	ORG0074	O-RING	X	X			
12	1	ORG0075	O-RING	X	X			X
13	1	PBC0228	PUMP CASING					
14	1	PIN0001	PIN					
15	1	RET0053	RETAINER	X				
16	1	SHA0130	SHAFT	X				
17	1	SNP0008	SNAP-RING	X	X			
18	1	SNP0011	SNAP-RING	X				
19	1	WER0001	WEAR PLATE	X	X			

PART LIST					
No.	QTY	PART NUMBER	PART NAME	MAT	DESCRIPTION
1	1	PUA0140	PUMP ASSY		JPR-YM06LY2

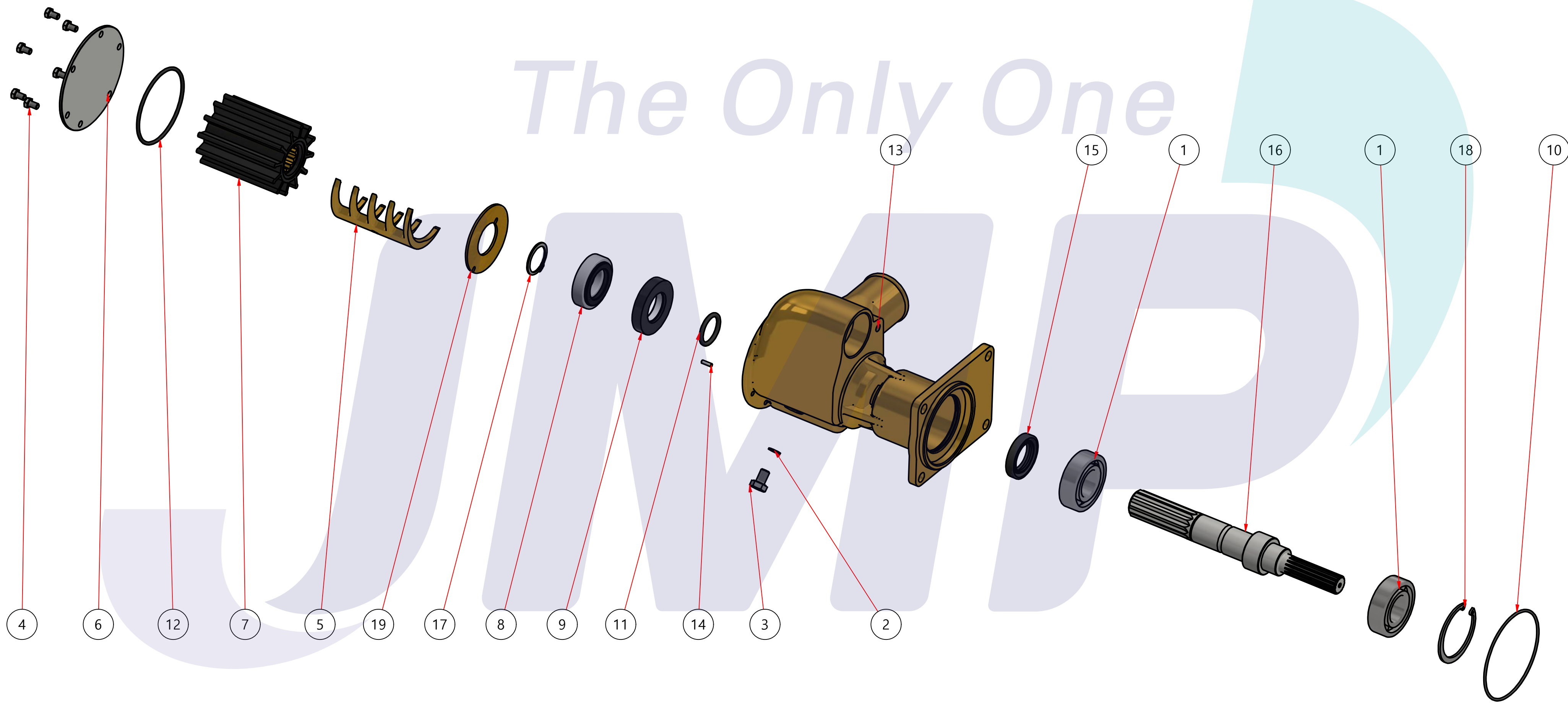

The Only One

Drawing by	Checked by	Approved by - date	Model Name	Date	Scale
M.J.KANG	C.I, JEON		JPR-YM06LY2	2016-11-09	1:1
			PUMP PART'S VIEW		
			PART NUMBER	Edition	Sheet
			PUA0140(0)	0	A2